



GW460

Solar Rattan Effect Stake Light (Pack of 4)

Information for use _____

Thank you for purchasing this product from STREETwize. The instructions written below provides you with guidance on how to get best use of the product. We highly advise that you read these instructions before using the product.

How It Works?

These stake lights are designed to be placed into soft ground in your garden. This includes garden beds, grassy paths and flower beds.

Each of these stake lights has its own solar panel which powers the LED lights inside. During the day, the solar panel absorbs direct sunlight which gets stored in the rechargeable battery. At night, the LED light inside the stake lights will illuminate using this stored energy, bringing charm and personality to your garden.

On First Use

Before using this product, remove the protective film from the solar panel.

We also advise that you fully charge the battery by placing the solar panel under direct sunlight for a full 24 hour period.

Where to Position The Solar Panel

The solar panel **MUST** be under **DIRECT SUNLIGHT** in order for the battery to charge.

We highly advise to avoid positioning the solar panel where there is a lot of shade or there is low light as this will prevent the battery from getting charged. And we also advise to not position the light near sources of artificial light that come on at night such as street lights as this will affect performance of light.

Other factors such as weather conditions and the number of hours of daylight will also affect the performance as well.

Usage Instructions

Set switch (located on the back of solar case) to “ON” position.

The lights will automatically charge under direct sunlight during the day time and illuminate at night.

NOTE: In order to verify that the switch is correctly in the “ON” position, cover the solar panel with your hand and the light should turn on automatically.

Maintenance & Troubleshooting

- Make sure the switch is set to “ON” position.
 - Keep the solar panel clean.
 - If a solar product does not light up after it has been used for around 8 – 12 months, replace the rechargeable battery as it may be weak or worn out. (Battery 1 pc 1.2V “AA” 600Mah, Ni-MH, Rechargeable). Never use another battery with a different spec.
-

Battery Replacement

1. Unscrew the battery compartment cover (found at the base) by using a Phillips head screwdriver (not included).
2. Open the compartment carefully and ensure that the battery terminals are not damaged.
3. Remove the old depleted battery and replace with 1 x new AA rechargeable battery.
4. Secure the battery compartment in place using the screws.

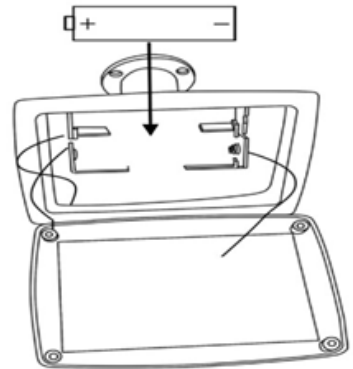

ATTENTION: Batteries must be recycled or disposed of in accordance with your local authority guidelines. Do not dispose of these near an exposed heat source or open flame or into your normal household waste. Remove the battery from the product if it is to be stored for a long period of time. Removal and/or replacement of the battery should only be carried out by an adult or under adult supervision.

Health & Safety

- Do not use the lights if the insulation or bulb have been damaged.
- Never allow the product to come into contact with excessive heat or naked flame.
- This product is not a toy. Keep away from pets and children, ensuring that children are supervised at all times.

Technical Specifications

Name

Solar Rattan Effect Stake Light (Pack of 4)

Supplier Code

GW460

Battery

1.2V AA 600mAH Ni-MH rechargeable battery



Streetwize:

Ashburton Road West, Trafford Park,
Manchester, M17 1RY

For Product Support:

E: support@streetwize.co.uk

T: +44 (0)161 447 8597

EU Regd. Address:

Ace Supply Co (Europe) Ltd. D02 A098, Republic of Ireland

www.streetwize.co.uk